

Countertop Receptacles

20A 125V Tamper-Resistant Pop-Up Kitchen Counter Receptacle

HUBBELL

Features

- Spill water tested
- Push down to pop-up function is rated for a minimum of 10,000 cycles
- Easy installations - simply drop in and tighten

Ordering information

Description	Finish	Color/Material	Surface Mount	Flush Mount	
20A 125V Tamper-Resistant Pop-Up Kitchen Counter Receptacle,	Brushed	Nickel	RCT220NI	RCT221NI	
		Aluminum	RCT220ALU	RCT221ALU	
		Brass	RCT220BR	RCT221BR	
		White	RCT220W	RCT221W	
	Powder Coated	Black	RCT220BK	RCT221BK	
		Polished	Chrome	RCT220CH	RCT221CH
		Matte	Black	RCT220BK	RCT221BK
			Bronze	RCT220BZE	RCT221BZE

Listings

cULus listed to UL498, section 146

Specifications

Cover and Flange	Die cast aluminum
Main Body	Engineered thermoplastic PBT
Wiring Chamber	Die cast aluminum
Water Seals	Elastomers and silicon

Performance

Electrical

Configuration	20 amp 125 volt, Tamper Resistant Receptacle
Circuit Rating	20 amp non-feed through
Dielectric Voltage	Withstands 1,500V minimum

Mechanical

Terminal Accommodation	#12 AWG copper stranded or solid conductor
Terminal Identification	Terminals identified in accordance with UL498 and CSA

Environmental

Flammability	UL94V-2
Operating Temperature	Maximum continuous 75C, minimum -40C (w/o impact)

Dimensions (mm)

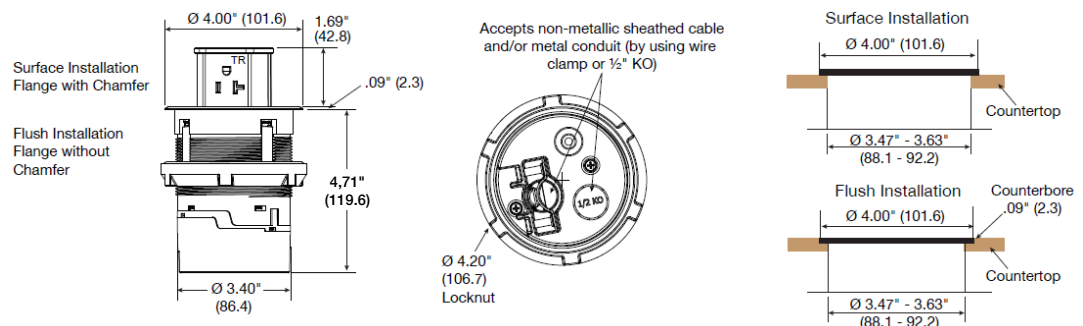

HUBBELL[®]
Wiring Device-Kellems

www.Hubbell.ca/wiring



HUBBELL CANADA • COMMERCIAL & INDUSTRIAL
870 Brock Road South • Pickering, ON L1W 1Z8 • Tel. : (905) 839-1138 • Fax : (905) 839-9108

H3603
02/2019